

Installation Instructions

(Translation of the original installation instructions)



Inlinedrive ID11 System

Document revision history

| Version | Date | Modification, change |
|---------|-------|----------------------|
| (-) | 05/11 | First release |
| (a) | 12/11 | Operations |

Disclaimer and Exclusion of Liability

PHOENIX MECANO is not responsible for damage resulting from:

- failure to observe these instructions,
- changes made to this product which have not been approved by PHOENIX MECANO, or
- the use of replacement parts which have not been approved or manufactured by PHOENIX MECANO.

Manufacturer's address

DEWERT Antriebs- und Systemtechnik GmbH

Weststraße 1

32278 Kirchlengern

Germany

Tel: +49(0)5223/979-0

Fax.: +49 0 522375182

<http://www.dewert.de>

Info@dewert.de

Address of distributor

OKIN Motion Technologies GmbH

Friedrich-Ebert-Straße im Campus 1

51429 Bergisch Gladbach

Germany

Tel: +49(0)2204/48022-0

Fax.: +49(0)2204/48022-118

<http://www.okin.de>

Info@okin.de

Creation of a complete operating instruction manual for the entire end product

These instructions are only intended to be used by the end-product manufacturer. They should not be given to the operator of the end product. The factual information contained within may be used as a basis when creating the end-product manual.

The warning and danger notices are best suited for use in the end product's manual. However it is not sufficient to simply follow these notices. You should also carry out an internal risk assessment for your end product. This can then be used as the basis for the safety notices in your manual.

Document revision history3

Disclaimer and Exclusion of Liability3

Manufacturer's address3

Address of distributor3

Creation of a complete operating instruction manual for the entire end product.....4

1. General information.....7

1.1 About these instructions7

1.2 Availability of this document7

1.3 Conventions used8

2. Safety Instructions9

2.1 Proper and Intended Usage.....9

2.2 Selection and qualification of personnel10

2.3 Notice on safety during operations10

3. System component description11

3.1 Assembled complete system (Example: basic version)11

3.2 Motion Manager 2 / 3 Control Units12

3.3 Control keypads14

3.4 Lifting column Inlinedrive ID1115

4. Configuring the Inlinedrive ID11 System16

5. Installation.....18

5.1 Safety notices to observe during installation18

5.2 Installing the Inlinedrive ID11 lifting columns.....20

5.3 Installation of the Motion Assist Control Keypad25

5.4 Installation of the Motion Assist Pro control keypad26

5.5 Mounting the Motion Manager 2/3 Control Units27

5.6 Electrical connection of the Motion Manager 2 / 3 Control Units.....31

6. Commissioning.....35

6.1 Reset during commissioning35

7. Operating Notes.....36

7.1 General information36

| | | |
|------------|---|-----------|
| 8. | Operation of the Motion Assist Control Keypad | 38 |
| 8.1 | Button functions of the Motion Assist Control Keypad | 38 |
| 8.2 | Raising and lowering the table | 38 |
| 8.3 | Turning the optional lighting on and off | 39 |
| 8.4 | Memory positions..... | 39 |
| 8.5 | Container stop positions | 39 |
| 8.6 | What to do in the event of an error..... | 41 |
| 9. | Operation of the Motion Assist Pro Control Keypad | 42 |
| 9.1 | Button functions of the Motion Assist Pro control keypad | 43 |
| 9.2 | Motion Assist Pro Control Keypad Display | 44 |
| 9.3 | Raising and lowering the table | 45 |
| 9.4 | Child Lock | 45 |
| 9.5 | Turning the optional lighting on and off | 45 |
| 9.6 | Memory Positions | 45 |
| 9.7 | Container stop positions | 46 |
| 9.8 | toggling the motor groups (optionally when more than three lifting columns are present) | 47 |
| 9.9 | Setting the clock..... | 48 |
| 9.10 | Height display of the table..... | 49 |
| 9.11 | What to do in the event of an error..... | 50 |
| 10. | Troubleshooting | 51 |
| 11. | Maintenance | 52 |
| 12. | Technical specifications and product designation..... | 54 |
| 12.1 | Motion Manager 2 / 3 control unit..... | 54 |
| 12.2 | Lifting column Inlinedrive ID11 | 56 |
| 12.3 | Labelling on the products | 58 |
| 13. | Disposal..... | 61 |
| | EU Declaration of Conformity | 62 |



1. General information

1.1 About these instructions

These installation instructions are not specific operating instructions for the end product, rather they contain a description of the functions of the control keypads Motion Assist and Motion Assist Pro (hereinafter referred to as "Motion Assist (Pro)") and the description of the installation of the system components in the Inlinedrive ID11 system:

- Lifting columns Inlinedrive ID11,
- Motion Assist (Pro) keypads,
- The Motion Manager 2 and Motion Manager 3 control units (hereinafter referred to as "Motion Manager 2/3").

These instructions will help you to minimize danger, repair costs and down times. They will also help you to maximize the reliability and lifespan of the end product.

| | |
|--|--|
|  CAUTION | |
|  | <p>The notices in these instructions must be followed! Following the guidelines during installation and connection procedures will help to minimize:</p> <ul style="list-style-type: none">• the risk of accident and injury, and• damage to the drive system or the end product. |

These installation instructions have been written with due care and attention. However, we cannot guarantee that the data, images and drawings are complete and correct nor do we accept any liability for the information contained therein, unless required by law.

- ▶ We reserve the right to make unannounced technical changes in the course of our continual product improvement process!

1.2 Availability of this document



As manufacturer of the end product, you are obligated to comply with Machinery Directive 2006/42/EC. This directive stipulates that the installation instructions must be kept on file for governmental inspection purposes.



1.3 Conventions used



Notices which do not relate to safety are indicated in these instructions with a symbol:

- ▶ Triangular notice symbol

Explanations of warning notices

| | |
|---|---|
|  |  DANGER |
| | DANGER indicates a hazardous situation which, if not avoided, will result in serious injury or death. |

| | |
|---|---|
|  |  WARNING |
| | WARNING indicates a hazardous situation which, if not avoided, could result in serious injury or death. |

| | |
|---|--|
|  |  CAUTION |
| | CAUTION indicates a hazardous situation which, if not avoided, could result in minor or moderate injury. |

| | |
|---|---|
|  | NOTICE |
| | NOTICE is used to address practices which are not related to personal injury but may result in damage to the product or surroundings. |



2. Safety Instructions

2.1 Proper and Intended Usage

The Inlinedrive ID11 System is intended:



- to adjust the heights of tables using the Motion Manager 2/3 controllers and PHOENIX MECANO lifting columns.



It may only be used for applications where unintended motion cannot lead to damage.



| | |
|---|---|
|  |  CAUTION |
| | <p>The Inlinedrive ID11 System should only be used for the applications described above. Any other form of usage is not permitted and can lead to accidents or destruction of the unit. Such non-approved applications will lead immediately to the expiration of all guarantee and warranty claims on the part of the end-product manufacturer against the manufacturer.</p> |

Improper usage

Be sure to follow the notices below concerning improper usage. You should include them in your product manual in order to inform the users of your end product.

| | |
|---|---|
|  |  WARNING |
| | <p>The Inlinedrive ID11 System should not be used:</p> <ul style="list-style-type: none"> • with a medical product, or installed in a medical product, • in any environment where combustible or explosive gases or vapours (e.g., anaesthesiology) may be present, • in the proximity of open fires or other heat sources (such as ovens or direct sunlight), • as a power source for toys or games, • in any application that will be cleaned with an automated washing system, • in a moist environment, or • outdoors. |

| | |
|---|---|
|  |  CAUTION |
| | <p>The Inlinedrive ID11 System may not be operated:</p> <ul style="list-style-type: none"> • by small children, • by frail or infirm persons without supervision, or • in the proximity of small children. |

| | |
|---|---|
|  |  CAUTION |
| | You should only use spare parts which have been manufactured or approved by PHOENIX MECANO. Only these parts will guarantee a sufficient level of safety. |

2.2 Selection and qualification of personnel

This Inlinedrive ID11 System should only be installed into the end product by someone who has completed training in electronic motor assembly or has equivalent qualifications.

You should only install this into the end product if you are qualified to do so. Otherwise, a properly qualified person should be found for this task.

2.3 Notice on safety during operations

Basic safety rules must be followed in order to ensure that the end product can be continually operated in a safe manner. These rules must be observed while using the end product and while installing the Inlinedrive ID11 System.



These rules and safety measures can be categorized as follows:

- Construction measures before the installation (refer to the "Operational safety" section in the "Installation" chapter).
- Safety fundamentals during the Inlinedrive ID11 System installation and during cable and wire routing (refer to the "Electrical connection" section in the chapter "Installation").
- Basic safety rules during operation (refer to the "Operating Notes" chapter).
- The creation of a manual for the end product which contains these and other safety rules.

Creating a user's manual

The manufacturer of the end product must create a manual for the users of that product. The safety notices in the end-product manual must be written based on the end product's risk assessment.

Electrical safety

| | |
|---|--|
|  |  WARNING |
| | There is a danger of electric shock! Be sure to unplug the power cord on the control unit before you begin assembly! |

3. System component description

The Inlinedrive ID11 System is used to adjust the heights of tables by using lifting columns and to move them to pre-programmed positions. The adjustments take place using a keypad Motion Assist (Pro) fixed to the table with the help of the controllers Motion Manager 2 / 3.

The variants of the Inlinedrive ID11 System depend on

- the type of the keypad,
- the number and working capacity of the connected lifting columns,
- the type and number of controllers connected,
- the optional table lighting.

3.1 Assembled complete system (Example: basic version)

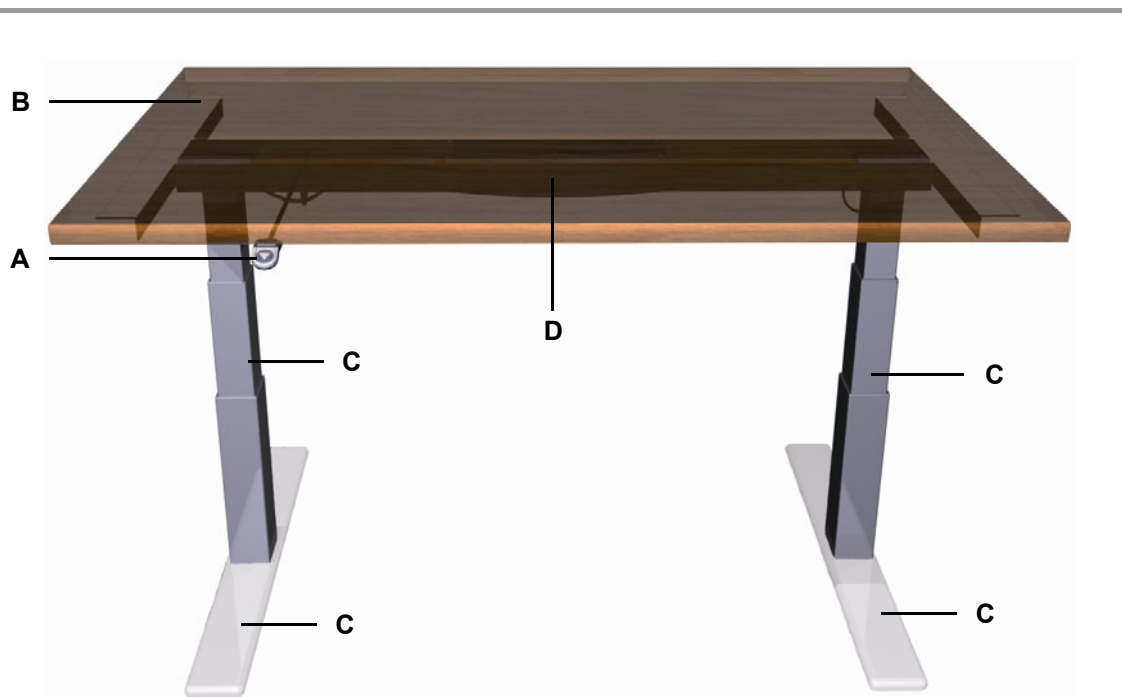

Figure 1 Inlinedrive ID11 System (Example: basic version for two lifting columns)

- | | |
|---------------------------------------|--|
| A Motion Assist Control Keypad | B Table top (example) |
| C Lifting column ID11 | D Motion Manager 2 or 3 controller (between the cross bars) |
| E Table base (example) | |

3.2 Motion Manager 2 / 3 Control Units

The housing for the Motion Manager 2/3 control units has connections for the power feed-in, for the lifting columns, and for a control keypad.

3.2.1 Motion Manager 2 control unit

The Motion Manager 2 is used to adjust two connected lifting columns.

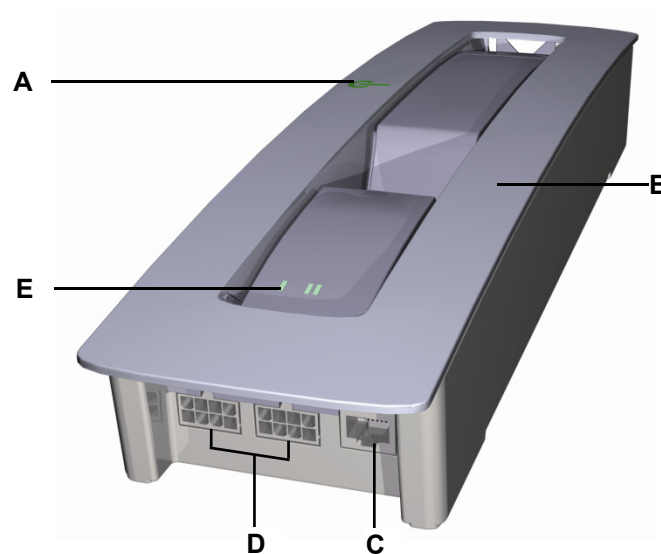

Figure 2 The components of the Motion Manager 2 control unit

- | | |
|--|-------------------------------|
| A Power LED | B Faceplate |
| C Keypad connection | D Lifting column ports |
| E Status LEDs for the connected lifting columns | |

3.2.2 Motion Manager 3 control unit

The Motion Manager 3 is used to adjust three connected lifting columns.

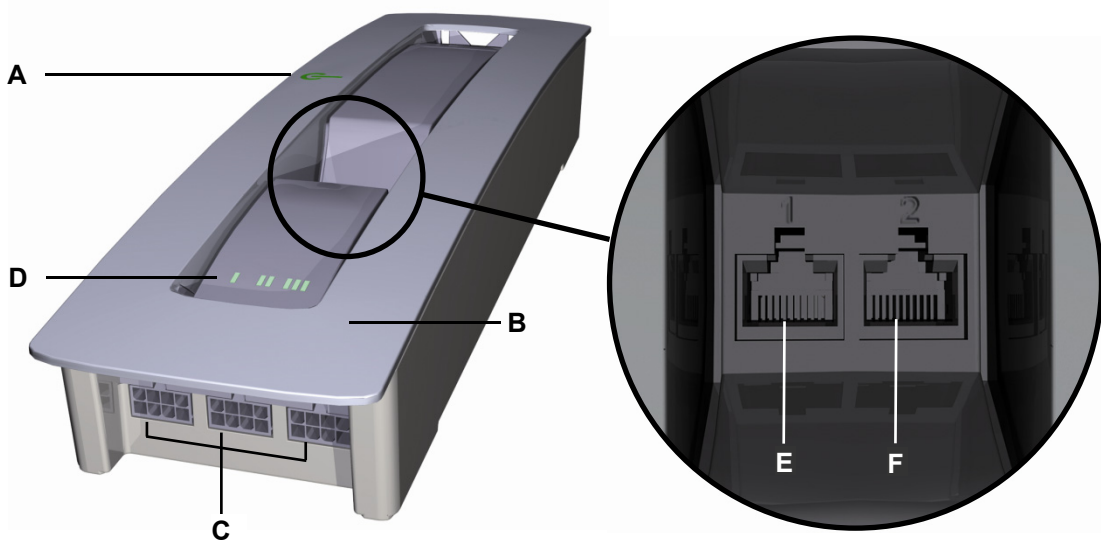

Figure 3 The components of the Motion Manager 3 control unit

- | | |
|-------------------------------|--|
| A Power LED | B Faceplate |
| C Lifting column ports | D Status LEDs for the connected lifting columns |
| E Keypad port | F Synchronous cable port |

3.3 Control keypads

The Motion Assist (Pro) keypads are used to adjust the table height. The table positions can be moved directly to the required position, or pre-programmed positions can be called up. The programming of these positions is also done using the Motion Assist (Pro) control keypads.

3.3.1 Motion Assist Control Keypad

The Motion Assist control keypad has two keys for movements up and down.

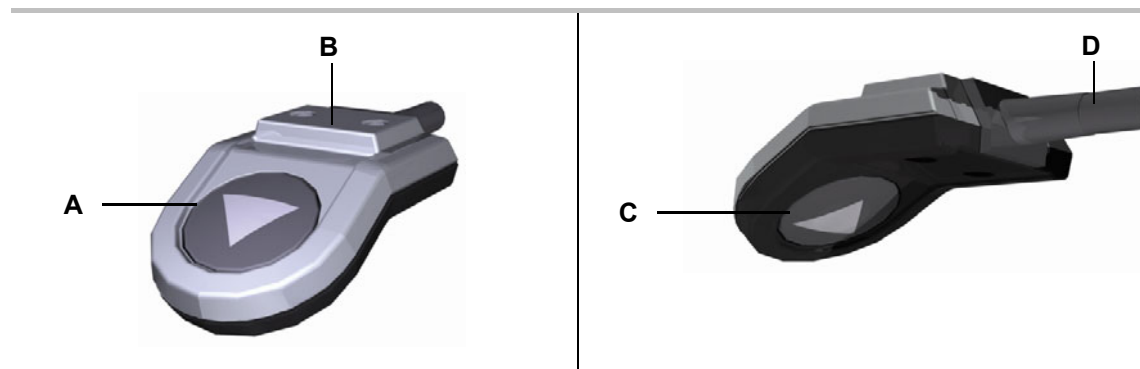

Figure 4 Motion Assist control keypad

- | | |
|--|---------------------------|
| A ▼-button (adjusting downward) | B Mounting surface |
| C ▲-button (upward adjustments) | D Connection cable |

3.3.2 Motion Assist Pro Control Keypad

The control keypad Motion Assist Pro has keys to adjust up and down as well as function keys to go to pre-programmed positions, or for additional functions (displacement measurement, time display and other functions).

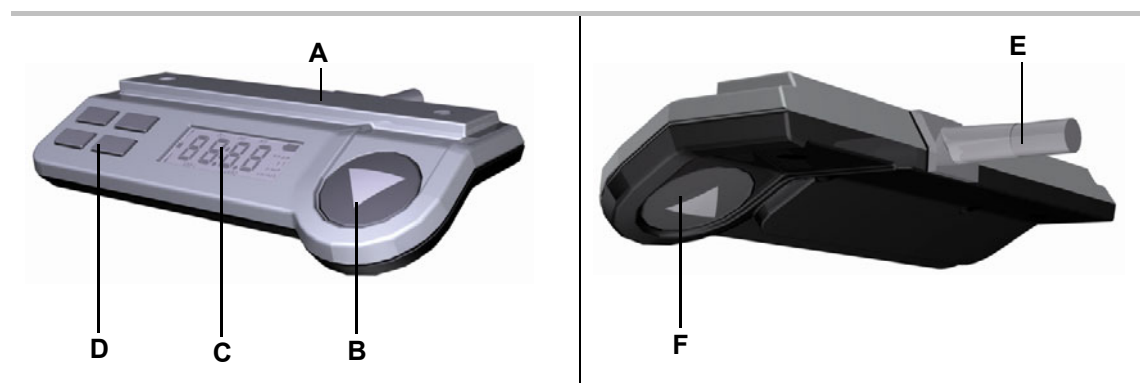

Figure 5 Motion Assist control keypad

- | | |
|---------------------------|--|
| A Mounting surface | B ▼-button (adjusting downward) |
| C Display | D Keys for memory positions |
| E Connection cable | F ▲-button (upward adjustments) |

3.4 Lifting column Inlinedrive ID11

The main components of the Lifting column Inlinedrive ID11 are the electric motor, the two telescopic columns that adjust, the outer column and the control cable for connection to the controller. The application will be attached to the head of the lifting column. At the foot of the lifting column a foot is attached. To enable the synchronization of the adjustment of multiple lifting columns, the Lifting column Inlinedrive ID11 is fitted with a position sensor.

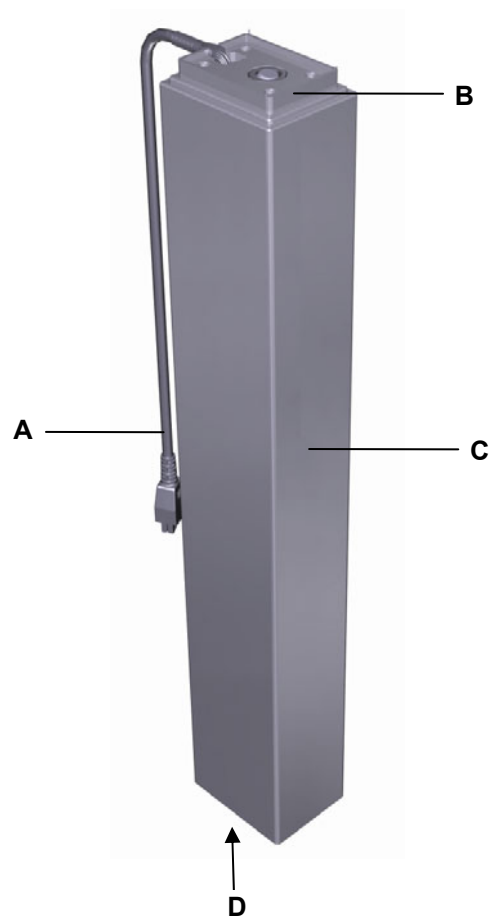

Figure 6 Major components of the Lifting column Inlinedrive ID11

- | | |
|--|-------------------------------------|
| A Control cable | B Head of the lifting column |
| C Outer column with two internal telescopic columns | D Foot of the lifting column |

4. Configuring the Inlinedrive ID11 System

The Inlinedrive ID11 System can, depending on the configuration, be combined with two, three, or more lifting columns. The following device combinations are offered:

Configuration 1: Motion Manager 2 control unit with two ID11 lifting columns and Motion Assist (Pro) control keypad

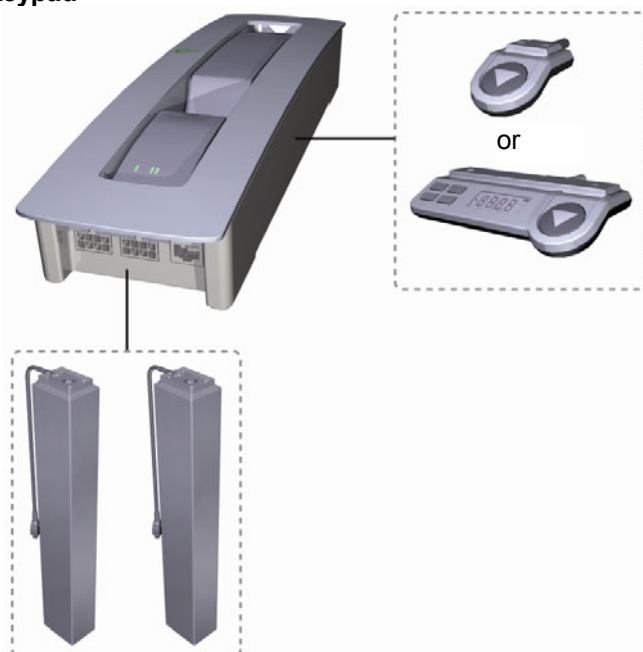

Installation steps:

- Installation of lifting columns (see section 5.2, page 20)
- Installation of control keypad (see section 5.3 or 5.4)
- Installation of control unit (see section 5.5, page 27)
- Connect the control keypad and the lifting columns to the control unit (see section 5.6.2, page 31)
- Connect the power supply cable (see section 5.6.4, page 33)

Configuration 2: Motion Manager 3 control unit with three ID11 lifting columns and Motion Assist (Pro) control keypad

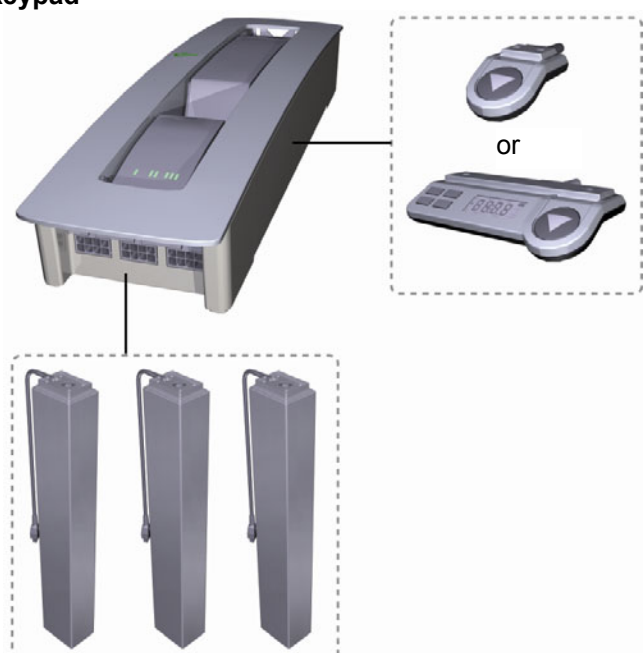

Installation steps:

- Installation of lifting columns (see section 5.2, page 20)
- Installation of control keypad (see section 5.3 or 5.4)
- Installation of control unit (see section 5.5, page 27)
- Connect the control keypad and the lifting columns to the control unit (see section 5.6.3, page 32)
- Connect the power supply cable (see section 5.6.4, page 33)

Configuration 3:
Two Motion Manager 3 control units with a maximum of six ID11 lifting columns and Motion Assist (Pro) control keypad

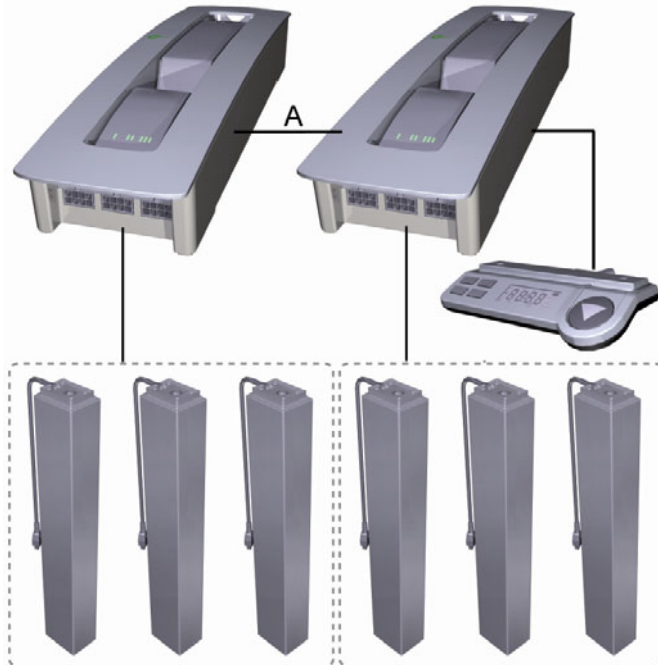

Installation steps:

- Installation of lifting columns (see section 5.2, page 20)
- Installation of control keypad (see section 5.4, page 26)
- Installation of control unit (see section 5.5, page 27)
- Connect the control keypad and the lifting columns to the control unit (see section 5.6.3, page 32)
- Connect the power supply cable (see section 5.6.4, page 33)
- ▶ For this configuration, a synchronising cable (A) is needed to connect the two control units.

Configuration 4:
Motion Manager 3 control units with two ID11 lifting columns, slave drive and Motion Assist Pro control keypad

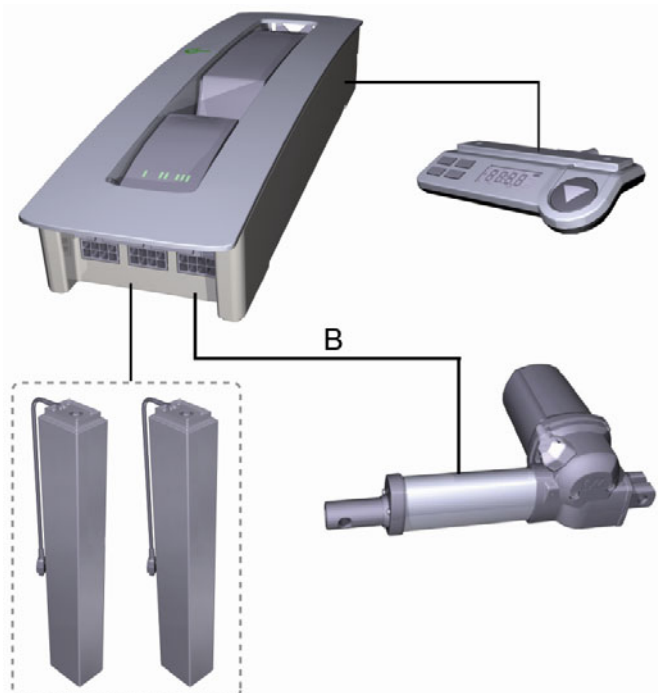

Installation steps:

- Installation of lifting columns (see section 5.2, page 20)
- Installation of the slave drive (see assembly instructions)
- Installation of control keypad (see section 5.4, page 26)
- Installation of control unit (see section 5.5, page 27)
- Connect the keyboard, the lifting columns and the slave drive (via an adapter) to the control unit (see section 5.6.3, page 32)
- Connect the power supply cable (see section 5.6.4, page 33)
- ▶ For this configuration, an adapter cable (B) is needed to connect the control unit and the slave drive.

5. Installation

5.1 Safety notices to observe during installation

Basic safety rules must be followed in order to ensure that the end product can be continually operated in a safe manner. These rules must be observed while using the end product and while installing the Motion Manager 2/3 control unit, the Motion Assist (Pro) control keypad, the InlineDrive ID11 lifting columns and the slave drive in the end product.

5.1.1 Avoiding electrical faults

Be sure to consider the length of the power cord when designing the dimensions for your end product in order to minimize the associated risks.

Routing the electrical cables

When routing the cables, be sure that:

- the cables cannot get jammed,
- no mechanical load (such as pulling, pushing or bending) will be put on the cables, and
- the cables cannot be damaged in any way.



Fasten all cables using sufficient strain relief and kink prevention methods.

5.1.2 Operational safety



The safety and reliability of the end product containing DEWERT components can be ensured by using the proper construction methods as described below.

Overheating



A temperature monitor shuts off the Motion Manager 2/3 control units if the overheat.

| | |
|---|--|
|  | CAUTION |
|  | The Motion Manager 2/3 control units are equipped with a thermal fuse that triggers when the unit overheats. If the temperature control has triggered, remove the control unit from the power supply, allow to rest for 20 - 30 minutes and try again. If the control unit still does not function, please contact your supplier / dealer. |

Avoiding fatigue fractures

|  CAUTION | |
|--|---|
|  | <p>Lifting columns that are incorrectly installed can undergo fatigue fractures which then create a risk of injury.</p> <ul style="list-style-type: none">• Install the lifting column in the end product so that it is properly aligned. This will help prevent shear stress.• Do not position the lifting column at a slanted angle when installing it in the end product. A slanted angle between the intended direction of movement of the end product and the lifting column's direction will create shear stress and could lead to a fatigue fracture. |

Avoiding a pinching hazard

|  CAUTION | |
|--|---|
|  | <p>When designing your end product, you should take the lifting column's adjustment movement into account with passive safety mechanisms and with the appropriate safety notices in your operating instructions.</p> <ul style="list-style-type: none">• Installation methods for ensuring passive safety: Install the lifting column Inlinedrive ID11 so that none of the positions where shear and pinch hazards exist are accessible externally. |

- ▶ When preparing safety notices for the operator, be sure that your operating instructions inform the user of these points.

5.2 Installing the Inlinedrive ID11 lifting columns

Before installing and connecting the Motion Manager 2/3 control units, make sure that you are observing all of the safety notices found in the "Safety notices to observe during installation" section.

5.2.1 Assembly table stand

- Use screws M6 (grade 8.8) of suitable length so that the depth is at least 9 mm and a maximum of 11 mm, as shown in Figure 7 (screw length = thickness of the base plate + min. 9 to max. 11 mm). The tightening torque must not exceed 10 Nm.

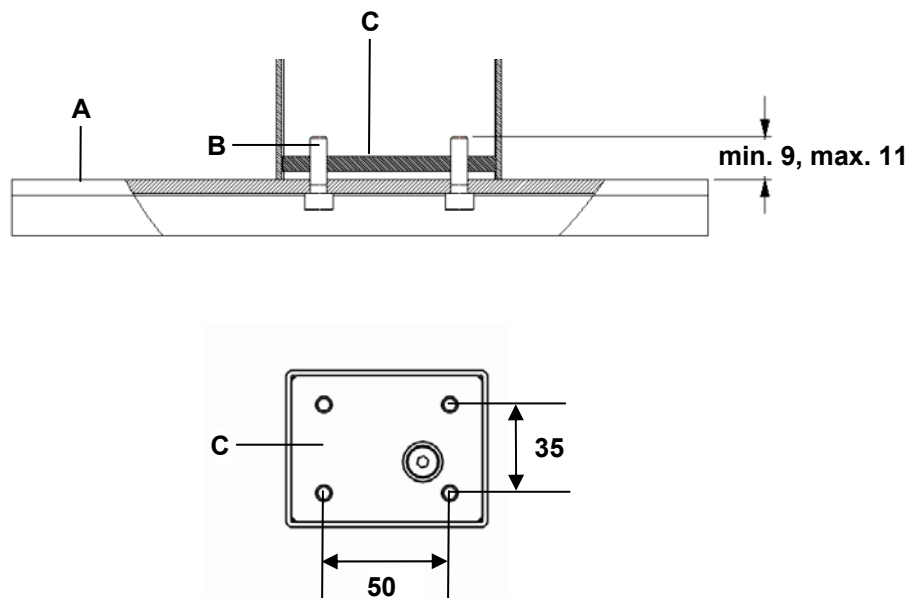

Figure 7 Mounting table stand: Screw depth and mounting dimensions (in mm)

- A** Foot of the application (table stand) **B** Screws M6 (8.8)
C Foot of the lifting column

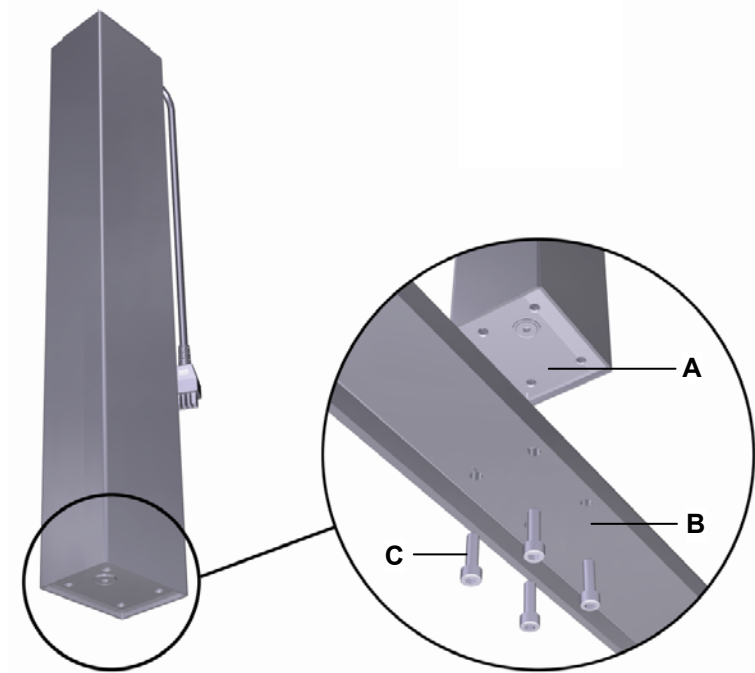

Figure 8 Mounting table stand

A Foot of the lifting column

B Table base

C Screws M6 (8.8)

- 1 Screw to the table base with four screws at the foot of the lifting column Inlinedrive ID11, as shown in Figure 8 (maximum tightening torque = 10 Nm). The mounting dimensions are shown in Figure 7.
- 2 Repeat step 1 with all other lifting columns.

5.2.2 Mounting table

- Use screws M6 (grade 8.8) of suitable length so that the depth is at least 9 mm and a maximum of 11 mm, as shown in Figure 9 (screw length = thickness of the table top + min. 9 to max. 11 mm). The tightening torque must not exceed 10 Nm.

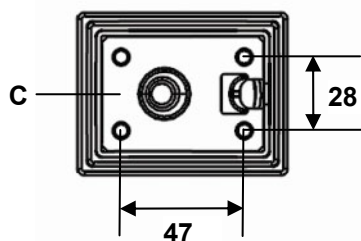
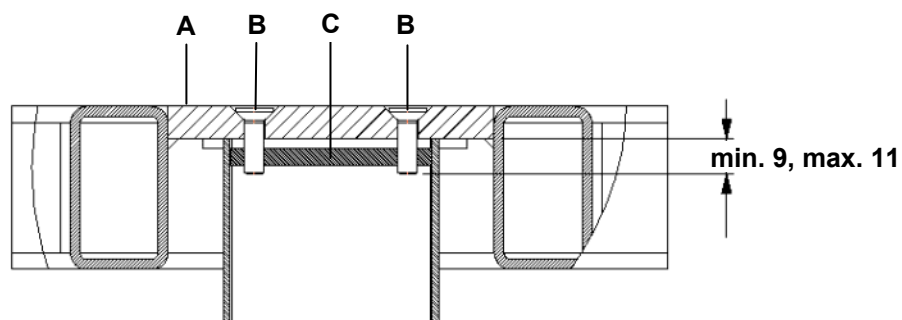

Figure 9 Assembly to the table mounting plate: Screw depth and mounting dimensions (in mm)

A Table mounting plate

B Screws M6 (8.8)

C Head of the lifting column

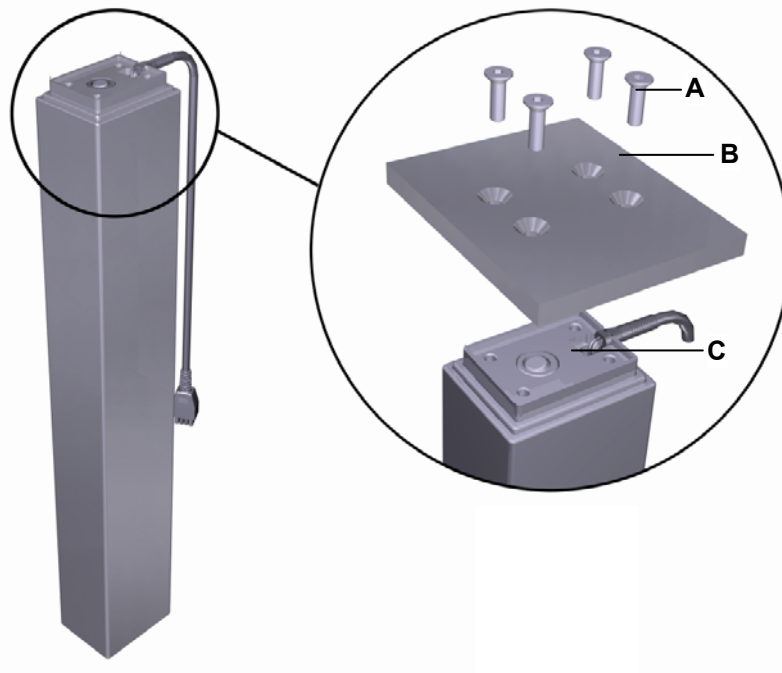

Figure 10 Mounting table top



A Screws M6 (8.8)

B Application (for example: Table mounting plate)

C Head of the lifting column

- ▶ It is recommended to carry out the installation with the table turned upside-down onto its top. Place the inverted table top on a suitable surface.
 - ▶ Optional: Place a steel plate provided with holes (not present at delivery) between the head of the column and the table top. A fitted steel plate will reduce the chances of any electrical equipment or monitors that are standing on the table suffering interference when the lifting column is being operated.
- 1 Screw the table mounting plate with four screws to the head end of the lifting column Inlinedrive ID11, as shown in Figure 10 (maximum tightening torque = 10 Nm). The mounting dimensions are shown in Figure 9.
 - 2 Attach any other lifting columns that are required to the respective mounting plates on the table.
 - 3 Turn the table over, when you have carried out the installation on an inverted table.

5.2.3 Dismantling the lifting column

| | |
|---|--|
|  |  CAUTION |
| | Work on electrical components can only be carried out with the controller's mains plug removed and/or the connection cable to the lifting column disconnected. |

► Certain details may change as a result of technical changes.

- 1 Move the table to the starting position, so that the lifting columns are fully retracted.
- 2 Pull out the controller's mains power plug!
- 3 Remove all connection cables from the lifting columns from the plug sockets on the controller.
- 4 It is recommended to carry out the dismantling with the table turned upside-down onto its top. Turn the table over and lay it with the table top resting on a suitable surface.
- 5 First, remove the lifting columns from the table. Unscrew the four screws from the head end of each lifting column Inlinedrive ID11.
- 6 If required, remove the table feet from the bottom ends of the lifting columns.

5.3 Installation of the Motion Assist Control Keypad

The Motion Assist control keypad is mounted with two screws under the table (under the front edge of the table) as shown in Figure 12.

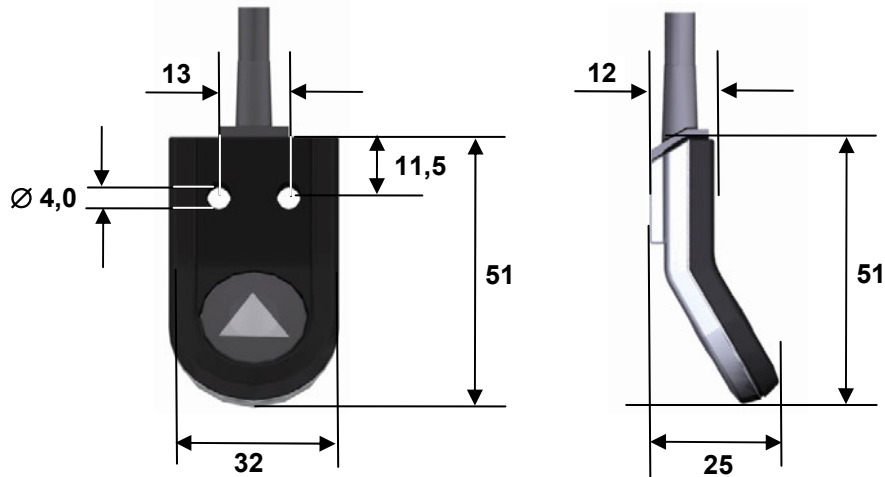

Figure 11 Motion Assist control keypad, installation dimensions (in mm)

5.3.1 Installation of the Motion Assist control keypad to the table top

- Use screws (B in Figure 12) which meet the requirements of DIN 7981 with $\text{Ø } 3.9 \text{ mm}$ and of suitable length (10 mm plus the screw-in depth into the table), screw head: $\text{Ø } 7.5 \text{ mm}$.

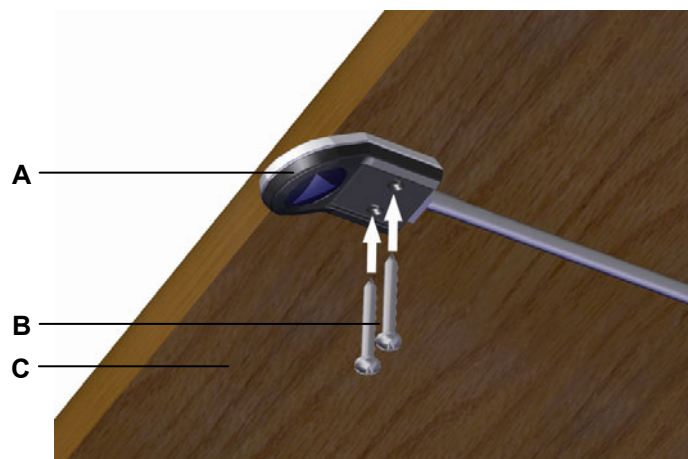

Figure 12 Installation of the Motion Assist Control Keypad

A Motion Assist control keypad

B Screws

C Table top

5.4 Installation of the Motion Assist Pro control keypad

The Motion Assist Pro control keypad is mounted with two screws under the table (under the front edge of the table) as shown in Figure 14.

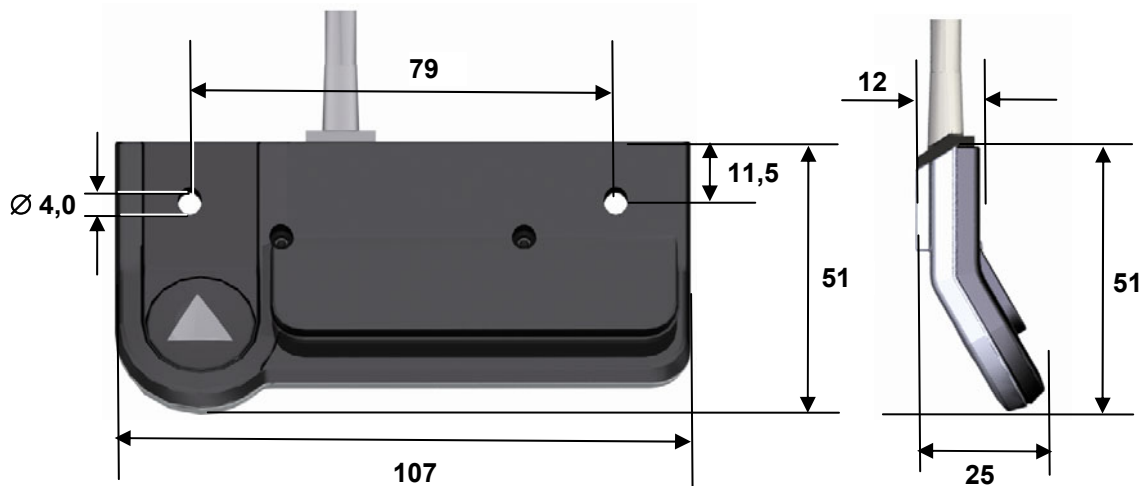

Figure 13 Motion Assist Pro control keypad, installation dimensions (in mm)

5.4.1 Installation of the Motion Assist Pro control keypad to the table top

- Use screws (B in Figure 14) which meet the requirements of DIN 7981 with $\varnothing 3.9$ mm and of suitable length (10 mm plus the screw-in depth into the table), screw head: $\varnothing 7.5$ mm.

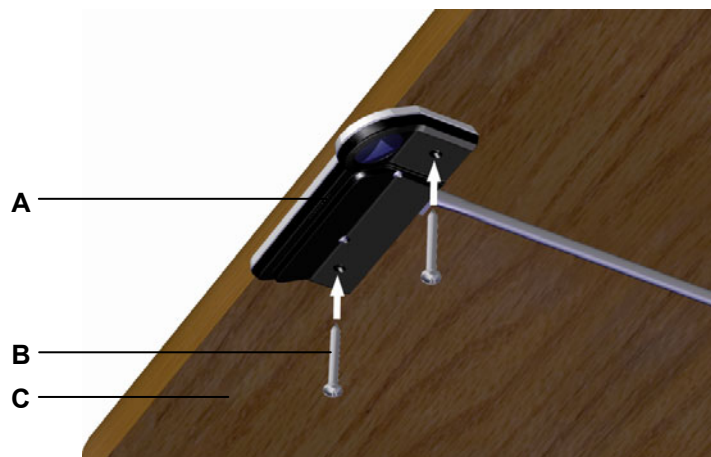

Figure 14 Installation of the Motion Assist Pro control keypad

- A** Motion Assist Pro control keypad **B** Screws
C Table top

5.5 Mounting the Motion Manager 2/3 Control Units

The control unit should be mounted in an appropriate manner under the table (refer to Figure 15). The control unit should be attached as close to the middle of the table as possible in order to ensure that the optical sensor functions properly. The control unit should lay flat and should not be subject to any torsion. A gap of at least 0.5 mm must be left between the sides of the control unit and the cross bars.

There are four screw holes located in the bottom of the control unit to use for mounting (refer to Figure 17). The connecting cable should be routed through the cable duct and cable guides (refer to Figure 15).

- ▶ Use screws meeting the requirements of DIN 7981 with \varnothing 4.8 mm and of suitable length (28 mm plus the screw-in depth into the table), screw head \varnothing 9.5 mm.

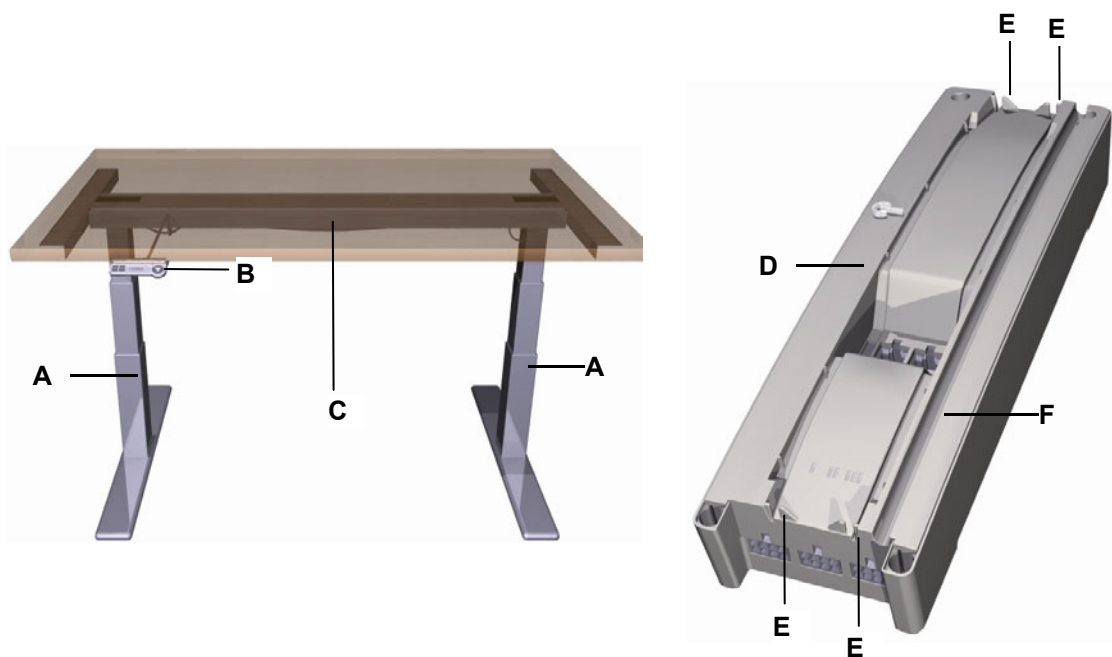



Figure 15 Table with attached Motion Manager 2/3 control unit and lifting columns

- | | |
|---|--|
| A Inlinedrive ID11 lifting column (example) | B Motion Assist Pro keypad (example) |
| C Motion Manager 2 / 3 controller (mounted between the cross bars) | D Control unit without faceplate |
| E Cable clamps for the keypad cable or the synchronous cable | F Cable duct for the lifting column cable |

| | |
|--|--|
|  |  CAUTION |
| You should only install and uninstall the control unit when it is completely disconnected from any live current! | |

- 1 Press on the inside of the control unit's faceplate (as shown in Figure 16) and then pull the faceplate away from the control unit.

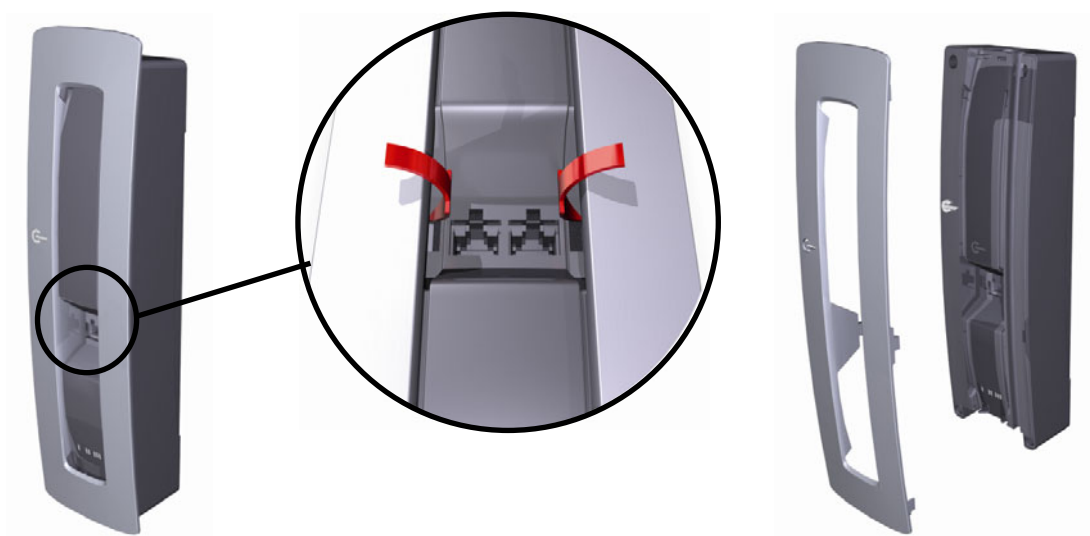

Figure 16 Mounting the Motion Manager 2/3 control unit

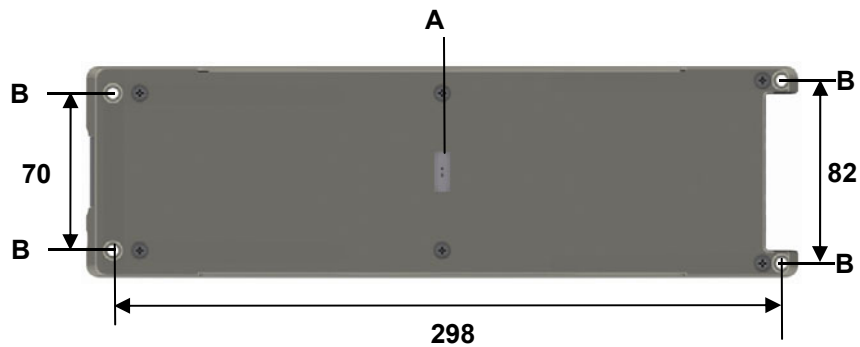

Figure 17 Dimensions of the Motion Manager 2/3 control unit, bottom view (in mm)

A Sensor

B Mounting holes (through holes in the bottom case of the control unit)

| NOTICE | |
|---------------|---|
| | <p>A sensor is located on the bottom of the control unit (labelled A in Figure 17). The accompanying label (included with delivery) should be used to ensure that the sensor functions correctly. The label should be positioned on the table where the sensor will contact it.</p> |

- 2 Stick the label on the spot on the table plate where the sensor is positioned. The label must be placed on a dust-free surface so that there are no air bubbles under it.

| NOTICE | |
|---------------|---|
| | <p>During the installation of the control unit under the table, a gap of at least 0.5 mm must be left between the sides of the control unit and the cross bars.</p> |

- 3 Screw the control unit onto the table. Use the mounting holes (B) shown in Figure 17 located on the bottom case of the control unit. Use screws meeting the requirements of DIN 7981 with \varnothing 4.8 mm and of suitable length (28 mm plus the screw-in depth into the table, screw head: \varnothing 9.5 mm).

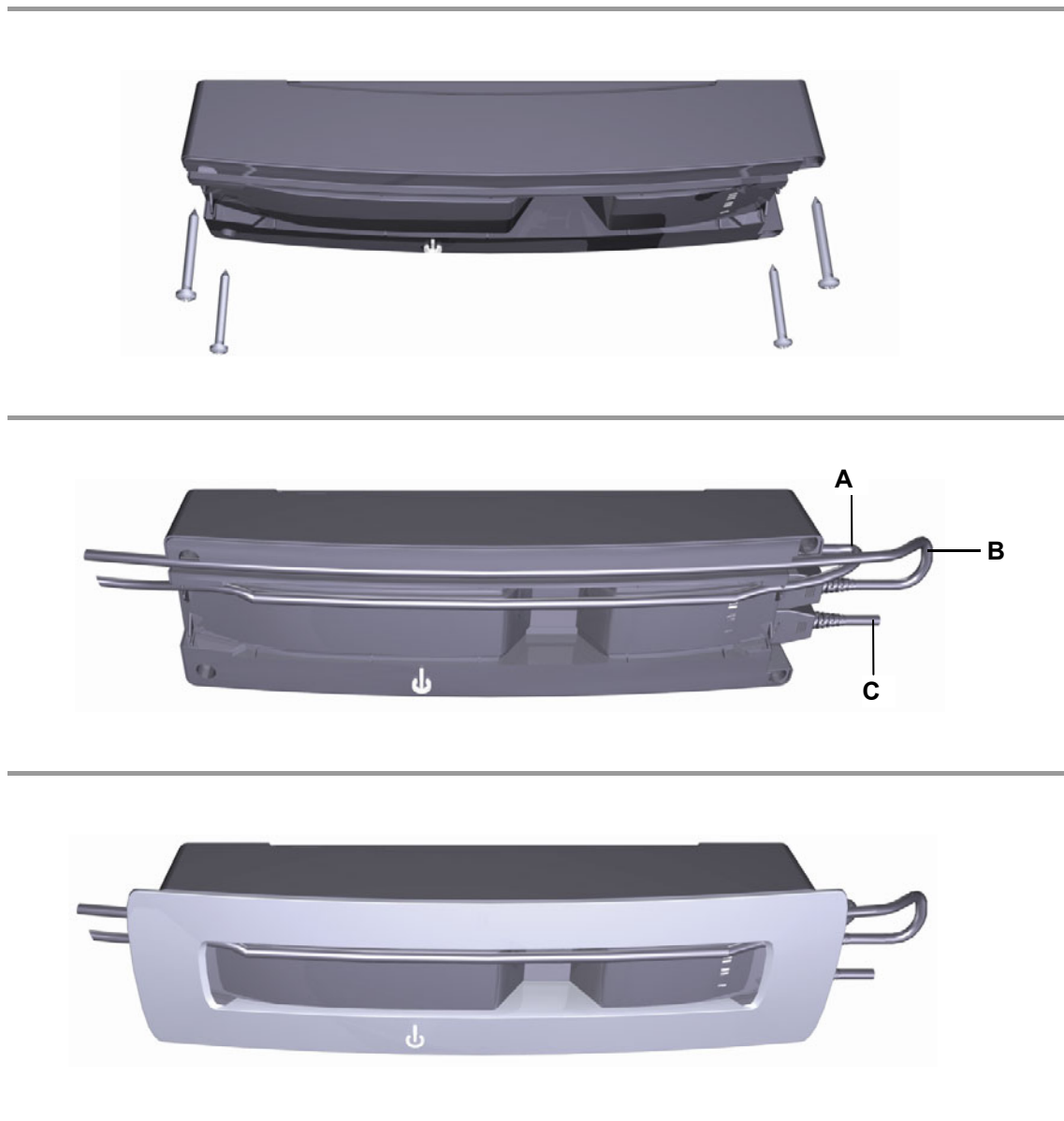

Figure 18 Mounting the control units (example of Motion Manager 2)

A Keypad cable

B Cable for lifting column 2



C Cable for lifting column 1

- 4 Route the lifting column cables, the keypad cable and/or the synchronous cable through the cable clamps on the control unit (refer to Figure 18).
- 5 Put the faceplate back on the control unit and press it down until you hear it snap in.



Follow the notice below when plugging the power plug into the power outlet:

| | |
|--|---------------|
| | NOTICE |
| There is a delay after the supply voltage is applied before the device actually turns on. Wait at least 15 seconds before commissioning. | |

5.6 Electrical connection of the Motion Manager 2 / 3 Control Units

| | |
|--|--|
|  CAUTION |  <p>Electrical components should be connected or disconnected only when the power supply cord is unplugged.</p> |
|--|--|

5.6.1

| | |
|---|---|
|  NOTICE |  <p>There is a delay after the supply voltage is applied before the device actually turns on. Wait at least 15 seconds before commissioning.</p> |
|---|---|

5.6.2 Connecting the lifting columns and the keypad to the Motion Manager 2 control unit

The Motion Manager 2 control unit is used for operating two lifting columns. The lifting columns and the keypad are connected on the front of the control unit. The following illustration shows the location of these connections.

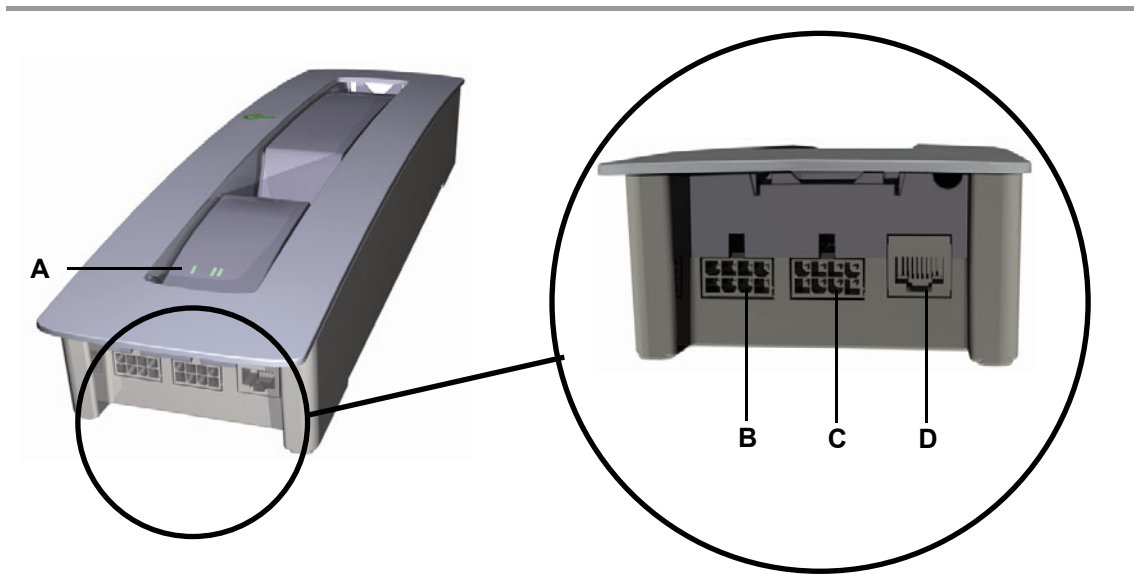

Figure 19 Connection ports on the Motion Manager 2 control unit: Model used for two lifting columns

- | | |
|--|---|
| <p>A Status LEDs</p> <p>C Connection for second lifting column</p> | <p>B Connection for first lifting column; additionally: Connection for a lamp using an optional adapter cable</p> <p>D Connection for control keypad (e.g. Motion Assist (Pro))</p> |
|--|---|

5.6.3 Connecting the lifting columns and the keypad to the Motion Manager 3 control unit

With the Motion Manager 3 control unit, for the operation of three and more lifting columns, the columns are connected to the front side of the control unit. The keypad is connected on the top of the Motion Manager 3 control unit. A synchronous cable can optionally be connected on the top of the control unit. The following illustrations show the locations for the keypad connections.

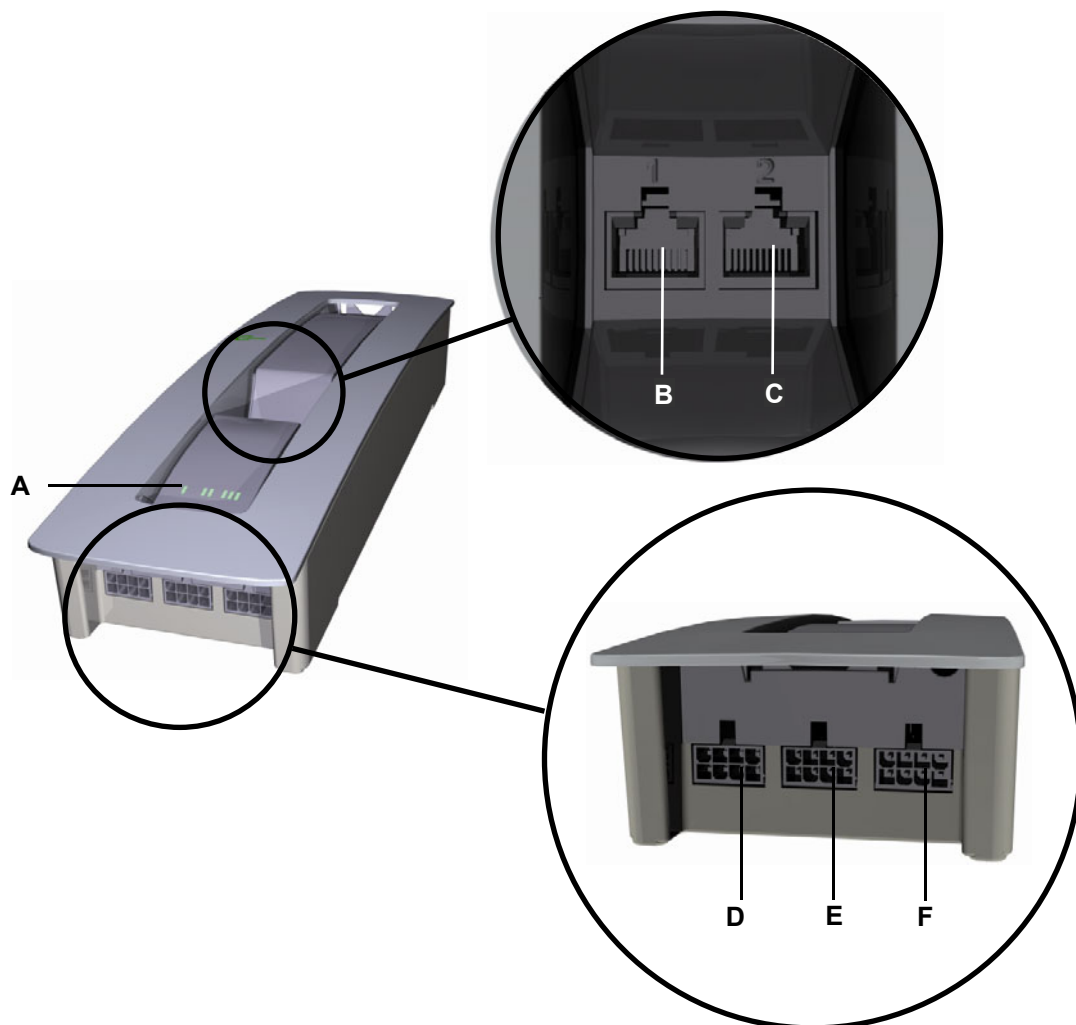



Figure 20 Connections for the lifting columns on the Motion Manager 3 control unit:
Model used for three or more lifting columns

- | | |
|--|---|
| A Status LEDs | B Connection for keypad (Motion Assist (Pro)) |
| C Connection for the optional synchronous cable | D Connection for first lifting column; additionally: Connection for a lamp using an optional adapter cable |
| E Connection for second lifting column | F Connection for third lifting column |

5.6.4 Mains power connection for the Motion Manager 2/3 control units

| | |
|--|------------------|
|  | ! WARNING |
| Please follow these operating instructions carefully. You could be injured by fire or electrical shock if you do not follow these assembly instructions. | |

The appropriate power cord is included, depending on the regional version (USA, continental Europe, the UK, Japan or Australia).

| | |
|--|------------------|
|  | ! WARNING |
| Only use the proper power cable that is permitted in your country. Be sure to use the correctly shaped plug, as shown in the following illustration. | |

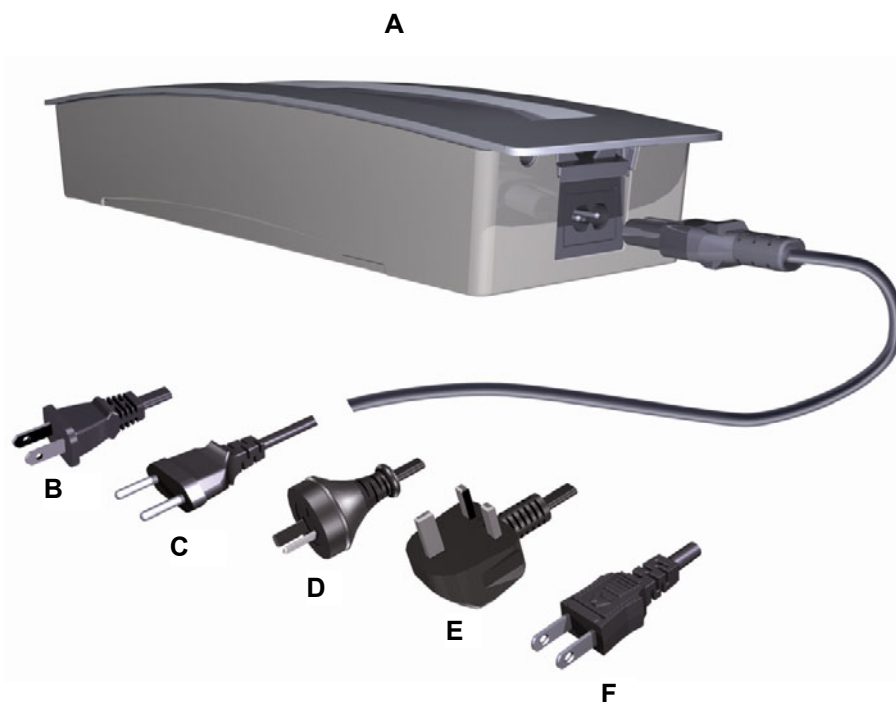

Figure 21 Power cord, regional variants

A Motion Manager 2/3 control unit

C Power plug (EURO version)

E Power plug (United Kingdom version)

B Power plug (USA version)

D Power plug (Australian version)

F Power plug (Japan version)

Follow the notice below when plugging the power plug into the power outlet:

| | |
|---|--|
|  | <p>NOTICE</p> <p>There is a delay after the supply voltage is applied before the device actually turns on. Wait at least 15 seconds before commissioning.</p> |
|---|--|

- ▶ You must reset the control unit after connecting the mains power supply. Various pre-programmed positions may be stored after the reset run. Additional information on commissioning and operating can be found in chapters 6 to 9.

5.6.5 Connecting the optional table lighting to the Motion Manager 2/3 control unit

The actual connections for the table lighting depend on the software configuration of the Motion Manager 2/3 control units. Make sure that your operating instructions inform the user of the end product about the specific connection for the table lighting.

Customer-specific lighting can be used. Use a suitable adapter cable. Obtain the pin-out assignments from the

6. Commissioning

| | |
|---|--|
|  | CAUTION |
| | Commissioning may only take place then the Inlinedrive ID11 System is fully installed (see chapters 4 and 5) and all components are connected. |

| | |
|---|--|
|  | NOTICE |
| | Before starting to commission, set the clock of the Motion Assist Pro keypad. To set the clock, please refer to section 9.9 "Setting the clock". |

6.1 Reset during commissioning

- 1 Connect the mains power plug to the socket on the control unit as shown in the electrical connections section in the installation chapter.
- 2 Insert the mains power plug into a power outlet. The Power LED lights up.
- 3 Observe the status LEDs displayed on the control unit. After connecting the power supply, the status LEDs light for the duration of the boot-up phase.
- 4 Wait until this boot-up phase has completed. The end of this phase is indicated during initial commissioning by the status LEDs blinking.
- 5 Press the  button (adjust downwards) for longer than 5 seconds, to perform the reset. The lifting columns move with reduced speed. A successful reset is indicated by five clicking noises.
- 6 After a few seconds the status LEDs will go out. This indicates that the control is operational again. You can now press the corresponding position to raise or lower the lifting columns.

Note: Reset during operation

If another reset drive is needed during operation (e.g. following a power cut), a

- programmed container stop function must be deactivated,
 - the time must be set on the Motion Assist Pro keypad.
- To deactivate container stops, please refer to the "Deactivation of Container stops" section, in the chapter "Operating" of your control keypad (chapter 8 or 9).
- To set the clock, please refer to section 9.9 "Setting the clock" in chapter "Operation of the Motion Assist Pro Control Keypad".

7. Operating Notes

The factual information contained within may be used when you are creating the end-product manual. The installation instructions do not contain all information required for the safe operation of the end product.

| | |
|--|----------------|
|  | CAUTION |
| When creating the operating instructions, remember that the installation instructions are intended for qualified specialists and are not for typical users of the end product. | |

7.1 General information

Delayed start-up

Follow the notice below when plugging the power plug into the power outlet:

| | |
|--|---------------|
|  | NOTICE |
| There is a delay after the supply voltage is applied before the device actually turns on. Wait at least 15 seconds before commissioning. | |

Power-on time / intermittent operations



The Motion Manager 2/3 control units have been designed for intermittent operations. Intermittent operation is an operational mode where the drive must pause after a specified maximum period of operation (power-on time). This protects the drive from overheating. In an extreme case, overheating can lead to a malfunction.



- ▶ The ratings plate on the drive specifies the maximum power-on time and the required pause intervals.

Avoiding electrical risks



| | |
|--|----------------|
|  | WARNING |
| Be sure that all live (current-carrying) parts of the drive system and power supply cannot be touched. In particular, be sure that unused power and control unit connections are covered adequately. | |

Power cord



| | |
|---|--|
|  |  WARNING |
| | Please follow these operating instructions carefully. You could be injured by fire or electrical shock if you do not follow these assembly instructions. |

| | |
|---|--|
|  |  WARNING |
| | Only use the proper power cable that is permitted in your country. Be sure to use the correct plug shape (refer to Figure 21). |

Reducing the risk of overheating with the thermal fuse

| | |
|--|--|
|  |  CAUTION |
| | The Motion Manager 2/3 control units are equipped with a thermal fuse that triggers when the unit overheats. If the temperature control has triggered, remove the control unit from the power supply, allow to rest for 20 - 30 minutes and try again. If the control unit still does not function, please contact your supplier / dealer. |



Emergency shut-off of the control unit

| | |
|---|--|
|  |  CAUTION |
| | In an emergency, disconnect the power plug of the Motion Manager 2/3 control unit in order to shut off the connected lifting columns. The power plug must always be accessible during operations so that emergency shut-off is possible. |

| | |
|---|--|
|  | NOTICE |
| | Before starting to commission, set the clock of the Motion Assist Pro keypad. To set the clock, please refer to section 9.9 "Setting the clock". |

Avoiding cable damage

Be sure that your operating instructions inform the user about the possible cable risks.

| | |
|---|--|
|  |  CAUTION |
| | The cables (particularly the mains cable) should not be run over. In order to prevent injuries or damage to the drive and control unit, no mechanical strain should be placed on the cables. |

8. Operation of the Motion Assist Control Keypad

The Motion Assist control keypad has  and  keys to make adjustments.













Figure 22 Function keys of the Motion Assist Control Keypad

A -button (adjusting downward)

B -button (adjusting upward) on the underside of the keypad



8.1 Button functions of the Motion Assist Control Keypad

| Key, key selection or key combination | Function |
|---|---|
|  | Adjusting downwards |
|  | Adjusting upwards |
|  | Disabling the container stop positions |
|  | Perform a reset-drive after a fault |
|  or  | Turn the optional lighting on or off |
|  and  | Programming the memory positions |
|  and  | Programming of the container stop positions |

8.2 Raising and lowering the table

Press the corresponding key on the keypad to raise or lower the table. Keep pressing the key until the desired height of the table is reached.

8.3 Turning the optional lighting on and off





Tap the  or  key briefly to turn the lighting on or off.

8.4 Memory positions

You can program two memory positions of the table. When adjusting the height of the table, it stops automatically when it reaches the pre-programmed memory position.

- ▶ When programming the container stop position (see Section 8.5 "Container stop positions") the memory positions are over-written!

8.4.1 Programming the memory positions

- 1 Press the  or  key and keep holding until the desired position is reached.
- 2 Press both keys simultaneously for more than 5 seconds to save the position. A double click sound indicates that the control unit is in storage mode.
- 3 Store the memory positions:
 - Upper memory position: Press  key until you hear a triple click.
 - Lower memory position: Press  key until you hear a triple click.
- 4 The memory positions are now saved.

8.4.2 Moving to the Memory position

Press the  or  key and keep holding until the desired memory position is reached.

- ▶ You can move past the memory positions. To move beyond a memory position, press the key again and hold it until the desired table position is reached.





8.5 Container stop positions

You can program two end positions of the table (container stop positions). The table stops at a container stop position, if they are programmed. The table cannot be moved beyond these positions.

| NOTICE | |
|---|--|
|  | Programming a container stop position is useful, a lower one for example, to prevent damage if there is equipment or other items stored or mounted under the table. This protection is not afforded by setting a memory position since they can be overridden by pressing the key again. |

- ▶ If there is a requirement to reset the drive control unit during operation, the container stop positions should be disabled before starting the drive reset.

8.5.1 Programming of the container stop positions

- ▶ Any stored memory positions are overwritten when the container stop positions are programmed!
- 1 Press the  or  key and keep holding until the desired container stop position is reached.
 - 2 Press both keys simultaneously for more than 5 seconds to save the position. A double click sound indicates that the control unit is in storage mode.
 - 3 Save the position as follows:
 - Upper container stop position: Press  key until you hear a triple click.
 - Lower container stop position: Press  key until you hear a triple click.
 - 4 Pull out the controller's power plug from the plug socket.
 - 5 The status LEDs on the Motion Manager 2 / 3 control unit will briefly flash. Wait until the status LEDs go out.
 - 6 Press and hold the  key while you insert the power plug of the controller keep pressing it until you hear a double click.
 - 7 The chosen container stop position is now enabled and can no longer be exceeded.



8.5.2 Disabling the container stop positions



- 1 Pull out the controller's power plug from the plug socket.
- 2 The status LED on the Motion Manager 2 / 3 control unit will briefly flash. Wait until the status LEDs go out.
- 3 Press and hold the  key while you insert the power plug of the controller keep pressing it until you hear a double click.
- 4 The container stop positions are now disabled.

8.6 What to do in the event of an error

A fault is indicated by one or more of the status LEDs on the control unit blinking. If an error occurs during operation (e.g. during table height adjustment) a drive reset must be carried out.

8.6.1 Drive Reset following problems occurring during operation of the Motion Assist control keypad

| | |
|---|---|
|  |  CAUTION |
| | Electrical components should be connected or disconnected only when the power supply cord is unplugged. |

- ▶ If a container stop position is programmed, it must be disabled before the drive reset (see action steps 1 through 3). If no container stop position is programmed, skip steps 1 to 3 and start with step 4.
- 1 Pull out the mains power plug.
 - 2 The status LEDs light up briefly. Wait until the status LEDs go out.
 - 3 Reconnect the mains power plug. Press  key immediately after plugging the power cord until you hear a double click sound, this indicates that the container stop positions are disabled. The container stop positions are now disabled.
 - 4 Press  key for more than 5 seconds to perform the drive reset. The lifting columns move with reduced speed.
 - 5 Adjust all the lifting columns until they are fully retracted (move the table to it's lowest position!).
 - 6 After a few seconds the status LEDs will go out. This indicates that the control is operational again. You can now press the corresponding position to raise or lower the lifting columns.

You can also reprogram any container stop positions (see "Programming of the container stop positions" in Section "Container stop positions")

9. Operation of the Motion Assist Pro Control Keypad















The Motion Assist Pro control keypad has, apart from the ▲ and ▼ keys, four function keys (1, 2, 3, M) and a display which shows the active settings and the time.



Figure 23 Motion Assist Pro control keypad function keys

- | | |
|---|---|
| A Key "1" for memory position M1 | B Key "2" for memory position M2 |
| C Key "3" for memory position M3 | D Key "M" used when programming the memory positions |
| E ▼-button (adjusting downward) | F ▲-button (adjusting upwards) on the underside |
| G Display | |

9.1 Button functions of the Motion Assist Pro control keypad

| Key, key selection or key combination | Function |
|--|---|
|  | Adjusting downwards |
|  | Adjusting upwards |
|  and  | Turn the child lock on or off |
|  and  | Changing the motor group |
|  | Turn the optional lighting on or off |
| 1 | Move to the memory position 1 |
| 2 | Move to the memory position 2 |
| 3 | Move to the memory position 3 |
| M | Save the memory positions |
| M | Selection of the unit for the table height display |
| M and  or  | Saving or deactivating the container stop positions |
| 1 and 2 as well as  and  | Activation or deactivation the motor group switching function |
| 2 and 3 as well as  or  | Setting the clock |
| 1 and 3 as well as  or  | Changing the measured height of the table |

9.2 Motion Assist Pro Control Keypad Display



Figure 24 Motion Assist Pro control keypad display

| Display | Explanation |
|---------|--|
| ↑ | Upper end position (container stop position) |
| ↓ | Lower end position (container stop position) |
| 🔒 | Child Lock |
| GRP1 | Display: Motor Group 1 |
| GRP2 | Display: Motor Group 2 |
| M1 | M1 indicates memory position 1 |
| M2 | M2 indicates memory position 2 |
| M3 | M3 indicates memory position 3 |
| ampm | Clock display mode |
| cm inch | Table Height unit display |
| ---g | Fault has occurred, error code e.g. "9" |

9.3 Raising and lowering the table

Press the corresponding key on the keypad (▲ or ▼) to raise or lower the table. Keep pressing the key until the desired height of the table is reached.

9.4 Child Lock

Turning on the child lock

- 1 Press the ▲ key and the "3" button simultaneously for 3 seconds. 🔒 flashes in the display for 3 seconds.
- 2 Activate the child lock by pressing the ▼ and ▲ keys simultaneously while it is flashing. 🔒 is now permanently on in the display. The keypad is now disabled.

Turning off the child lock

- 1 Press the ▲ key and the "3" button simultaneously for 3 seconds. 🔒 flashes in the display for 3 seconds.
- 2 Deactivate the child lock by pressing the ▼ and ▲ keys simultaneously while it is flashing. 🔒 is no longer shown in the display. The keypad is now unlocked.

9.5 Turning the optional lighting on and off

Tap the ▼ key briefly to turn the back-light on or off.

9.6 Memory Positions

You can program three memory positions of the table. When adjusting the height of the table, it stops automatically when it reaches a pre-programmed memory position.

- ▶ You can move past the memory positions. To move beyond a memory position, press the ▼ or ▲ key again and hold it until the desired table position is reached.
- ▶ Memory positions can not be deleted, only overwritten.

9.6.1 Moving to the Memory position



Press key "1", "2" or "3" and hold it until the desired memory position is reached. The display will show **M1**, **M2** or **M3** which indicates the memory position has been reached. This will be displayed as long as the key is pressed.

9.6.2 Programming the memory positions

- 1 Press the ▼ or ▲ key and keep holding until the desired table position is reached.
- 2 Briefly press the "M" button. The display will blink and show M1, M2 and M3 simultaneously for 3 seconds. While flashing, press the button "1", "2" or "3" to save the memory position.
- 3 The display will show M1, M2 or M3 to indicate that the position has been saved.

9.7 Container stop positions

You can program two end positions of the table (container stop positions). The table stops at a container stop position, if they are programmed. If an end position is reached, the display will indicate this by a blinking arrow.







- top position: 
- bottom position: 

The table cannot be moved beyond these positions.



| |
|---|
| NOTICE |
|  <p>Programming a container stop position is useful, a lower one for example, to prevent damage if there is equipment or other items stored or mounted under the table. This protection is not afforded by setting a memory position since they can be overridden by pressing the key again.</p> |



- ▶ If there is a requirement to reset the drive control unit during operation, the container stop positions should be disabled before starting the drive reset.



9.7.1 Programming the container stop positions

- 1 Press the  or  key and keep holding it until the desired container stop position is reached.
- 2 Save the position as follows:
 - Upper container stop position: Press the "M" and the  keys simultaneously for more than 5 seconds.
 - Lower container stop position: Press the "M" and the  keys simultaneously for more than 5 seconds.
- 3 The chosen container stop position is now enabled and can no longer be exceeded. The display will indicate if a position
 - has been programmed as the upper end position: 
 - has been programmed as the lower end position: 

9.7.2 Disabling the container stop positions



Press the  or  key and keep holding it until the container stop position you wish to disable is reached. Reaching the container stop position is shown in the display by the following arrow flashing:

- top position: 
- bottom position: 

- 1 Press the "M" and the  keys (lower end-position) or the  keys (upper end-position) simultaneously for more than 5 seconds to disable the current container stop position.
- 2 The disabled container stop position is no longer shown in the display.



9.8 Toggling the motor groups (optionally when more than three lifting columns are present)

9.8.1 Activating the toggling function of the motor groups



- 1 Press and hold the "1" and "2" keys simultaneously for more than 5 seconds. The display blinks for three seconds showing GRP1 and GRP2.
- 2 Press  and the  keys simultaneously for a short time while the GRP1 GRP2 flashes in the display. The display now permanently shows GRP1. The toggling function is now active and motor group 1 is active.

9.8.2 Changing the motor group

If you have activated the toggling function of the motor groups, you can choose between motor group 1 (synchronous operation of motor output 1 and 2 of the controller) and motor group 2 (motor output 3 of the controller).

- 1 Press the  and  keys simultaneously for 3 seconds. The controller switches to the other motor group. The display shows GRP1 when motor group 1 is activated and GRP2 when motor group 2 is activated.







9.8.3 Deactivating the motor group toggling function

- ▶ You should only turn off the toggling function when a synchronous operation of all three motor outputs from the control unit is possible.
- 1 Press and hold the "1" and "2" keys simultaneously for more than 5 seconds. The display blinks for three seconds showing GRP1 and GRP2.
 - 2 Press  and the  keys simultaneously for a short time while the GRP1 GRP2 flashes in the display. The active motor group display, GRP1 or GRP2 will no longer be shown. The toggle function is now disabled.
 - 3 Perform a drive reset to restore synchronous operation. The procedure to do this is described in section 9.11 "What to do in the event of an error".

9.9 Setting the clock

| | |
|---|---|
|  | NOTICE |
| | <ul style="list-style-type: none">• Before commissioning, set the clock (see chapter 6 “Commissioning”).• You should also set the clock following a power failure. |

Choosing between 12 and 24 hour display, setting the time

- The following steps only describe the use of the  key. Instead of the  key, the  key can also be used.
- 1 Press the "2" and "3" buttons simultaneously for three seconds or until am or pm blink in the display (12 hour) or neither of them (24 hour display).
 - 2 Press the  key until am, pm or neither is displayed.
 - Permanent display am: 12-hour clock (time setting in the morning).
 - Permanent display pm: 12-hour clock (time setting in the afternoon).
 - Nothing displayed: 24-hour clock.
 - 3 Press the "1" key. The hours display will flash. Set the hours using the  key.
 - 4 Press the "1" key. The minutes display will flash. Set the minutes using the  key.
 - 5 Press "1" again to leave the menu. The time is displayed as set.

9.10 Height display of the table







9.10.1 Metric or imperial measurements

Press the "M" key for 4 seconds. The displayed unit of the table height changes.

- ▶ The factory default setting is in centimetres. By pressing the "M" key (4 seconds) you can toggle between the units, cm and inches.

9.10.2 Changing the measured height of the table

The standard height of 68.0 cm is installed in the Motion Assist Pro control keypad when manufactured. If the actual height of the table is different, you can change the setting manually. Following this adjustment the actual display of the table height will be displayed in the Motion Assist Pro correctly.

- ▶ The following steps only describe the use of the  key. Instead of the  key, the  key can also be used.
- 1 Press "1" and the "3" button simultaneously for 5 seconds until the first number flashes in the display. Press the  key until the first digit of the height is correctly shown in the display.
 - 2 Press the "1" key. The second digit of the height flashes in the display. Set the second digit using the  key.
 - 3 Press the "1" key. The third digit of the height flashes in the display. Set the third digit using the  key.
 - 4 Press the "1" key. The last digit of the height flashes in the display. Set the last digit using the  key.
 - 5 Press "1" again to leave the menu.

9.11 What to do in the event of an error





A fault is indicated by one or more of the status LEDs on the control unit blinking. If an error occurs during operation (e.g. during table height adjustment) a drive reset must be carried out.

9.11.1 Reset-drive following problems occurring during operation of the Motion Assist Pro control keypad

| | |
|---|---|
|  | CAUTION |
| | Electrical components should be connected or disconnected only when the power supply cord is unplugged. |



| | |
|---|--|
|  | NOTICE |
| | Before starting to commission, set the clock of the Motion Assist Pro keypad. To set the clock, please refer to section 9.9 "Setting the clock". |

- ▶ If a container stop position is programmed, it must be disabled before the drive reset (see action steps 1 through 3). If no container stop position is programmed, skip steps 1 to 3 and start with step 4.

- 1 A programmed container stop position must be disabled before the reset trip. Press the  key and keep holding it until the container stop position you wish to disable is reached. Reaching the container stop position is shown in the display by the appropriate arrow flashing:
 - Achieving the lower end position: 
- 2 Press the "M" and the  keys (lower end position) simultaneously for more than 5 seconds to disable the container stop position.
- 3 The disabled container stop position is no longer shown in the display.
- 4 Press the  button and hold it until the lifting columns are fully retracted, this will be indicated by a 5-fold clicking sound. The drive reset is then successfully concluded.

10. Troubleshooting

This chapter contains remedial actions should any malfunctions occur. If you experience an error that is not listed in this table, please contact your supplier.

| | |
|---|--|
|  |  CAUTION |
| | <p>Only qualified specialists who have received electrician training should carry out troubleshooting and repairs.</p> |

| Problem | Possible cause | Solution |
|---|--|---|
| The lifting column or control unit is not functioning. | There is no mains supply voltage. | Connect the mains power. Perform a drive reset. |
| | Lifting column, control keypad or control unit is defective. | Please contact your supplier or sales agent. |
| The lifting column suddenly no longer moves. | The overheating protection or system protection has been triggered. | Remove the overload (change or remove the load). Check for any objects that are obstructing the movement of the table. Allow the system to rest for 20 to 30 minutes with the mains power unplugged. If this does not resolve the problem, contact your supplier or distributor. |
| | The unit's fuse may have been triggered. | Please contact your supplier or sales agent. |
| | There is no mains supply voltage. | Connect the mains power. |
| | A cable has been disconnected (mains power, lifting column or control keypad). | Check the cables and reinsert them, if required. |
| One or more status LEDs are blinking on the control unit. | Malfunction of the corresponding lifting column(s). | Check the lifting column connection cable. Perform a drive reset. If this does not resolve the problem, contact your supplier or distributor. |
| All status LEDs are blinking on the control unit. | Power failure during lifting column operation. | Perform a drive reset. If this does not resolve the problem, contact your supplier or distributor. |

11. Maintenance

- ▶ You should only use spare parts which have been manufactured or approved by PHOENIX MECANO. Only these parts will guarantee a sufficient level of safety.

| Type of check | Explanation | Time interval |
|---|--|---|
| Check the function and safety of the electrical system. | A qualified electrician should carry out this inspection. | Periodic inspections can be carried out at intervals based on the risk assessment which you conduct for your end product. |
| Look over the housing periodically for any signs of damage. | Check the housing for breaks or cracks. The IP-class protection will be impaired by any breakage or cracks. | At least every six months. |
| Look over the plug-in connections and electrical access points for signs of damage. | Check that all electrical cables and connections are firmly seated and correctly positioned. | At least every six months. |
| Look over the cables for any signs of damage. | Check the connecting cables for pinching or shearing. Also check the strain relief and kink protections mechanisms, in particular after any mechanical load. | At least every six months. |
| Periodic functional test of the control keypad. | Move the drive to the end positions in order to test the end switches. | At least every six months. |

Cleaning and care

The Inlinedrive ID11 System was designed to be easy to clean. The smooth surfaces can be conveniently cleaned.

| | |
|---|---|
|  | NOTICE |
| | Never clean the Inlinedrive ID11 System in an automated washing system or with a high-pressure cleaner. Do not allow fluids to enter the system. Damage to the control keypad could result. |

- 1 Always disconnect the mains power plug before you start to clean the unit!
- 2 Clean the lifting column Inlinedrive ID11 with a dry cloth.
- 3 Clean the Motion Manager 2 / 3 control unit and the Motion Assist (Pro) control keypads with a damp cloth.
- 4 Be sure that you do not damage the connection or power cables during the cleaning.

| | |
|---|---|
|  | NOTICE |
| | Do not use a cleanser that contains benzene, alcohol or similar solvents. |

12. Technical specifications and product designation

12.1 Motion Manager 2 / 3 control unit

| | |
|--|--|
| Mains power connection | 100 - 240V AC, 50/60Hz |
| Current consumption at nominal operations | Max. 2.5 A (depending on input voltage) |
| Fuse | T 4.00 A |
| Mode of operations ¹ | Intermittent duty 2 min. /18 min. Max. 8 A per channel and socket |
| Standby power consumption | ≤ 0.5 W |
| Protection classification | II |
| Protection degree | IP20 |
| Colours | Refer to sales brochure |
| Outlet for light | 12 V, 350 mA |
| Dimensions and weight | |
| Length x width x height | 352 mm x 94 mm x 59 mm |
| Weight | approx. 750 g |
| Ambient conditions for operation, storage and transport | |
| Transport / storage temperature | From -20 °C to +50 °C From -4 °F to +122 °F |
| Operating temperature | From +10 °C to +40 °C From +50 °F to +104 °F |
| Relative humidity | From 30% to 75% |
| Air pressure | From 700 hPa to 1060 hPa |

¹ Mode of operation: intermittent duty 2 min. /18 min. This means that after the unit is operated with its rated load for up to two minutes it must then be paused for 18 minutes. The system can malfunction if this pause is not observed!

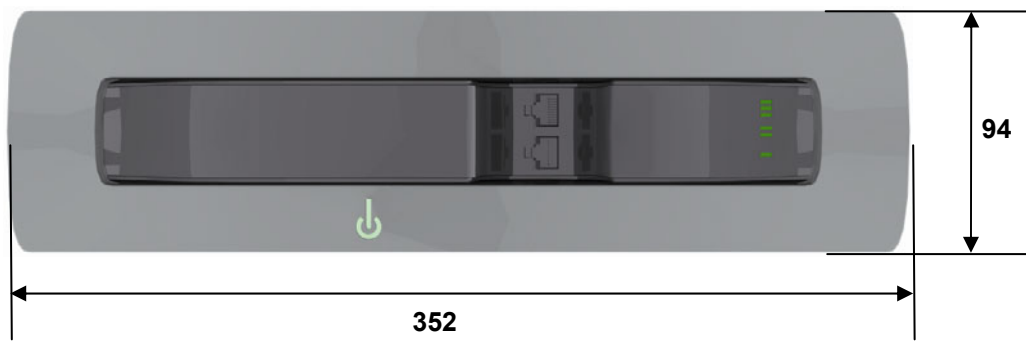

Figure 25 Dimensions of the Motion Manager 2 / 3 control unit, top view (in mm)



Figure 26 Dimensions of the Motion Manager 2 / 3 control unit, side view (in mm)

12.2 Lifting column Inlinedrive ID11

| | |
|--|---|
| Input voltage | 24 V DC |
| Current consumption at rated load | Max. 7.0 A DC |
| Permitted push force | max. 800 N |
| Bending moment, dynamic | <150 Nm (in the y direction, see Figure 28) |
| Torsional moment, static | < 200 Nm |
| self-locking | 1000 N |
| Mode of operation ¹ under max. rated load | Intermittent duty: 2 min./18 min. |
| Protection classification | III |
| Noise level | ≤ 48 dB(A) |
| Drive type | lifting column |
| Protection class | IP20 |
| Stroke | 660 mm |
| Colours | Refer to sales brochure |
| Length ² x width x height | 520 mm x 80 mm x 62 mm |
| Weight | approx. 7.8 kg |
| Cable length: | 1200 mm |
| Ambient conditions for operation, storage and transport | |
| Transport / storage temperature | From -20 °C to +50 °C From -4 °F to +122 °F |
| Operating temperature | From +10 °C to +40 °C From +50 °F to +104 °F |
| Relative humidity | From 30% to 75% |
| Air pressure | From 700 hPa to 1060 hPa |

¹ Mode of operation: intermittent duty 2 min./18 min. This means that after the unit is operated with its rated load for up to two minutes it must then be paused for 18 minutes. The system can malfunction if this pause is not observed!

² Length when retracted.

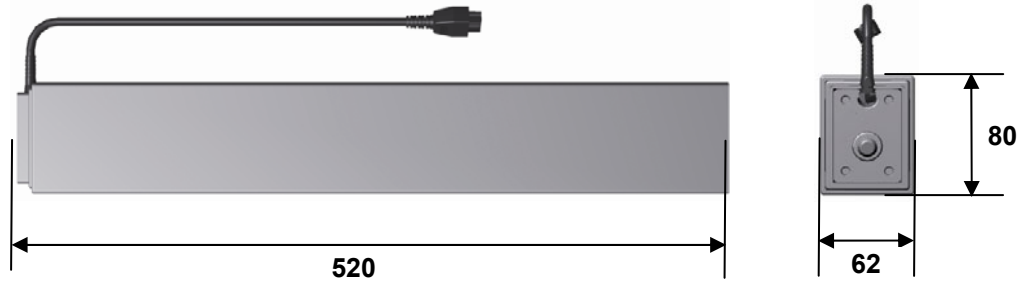

Figure 27 Dimensions of the Lifting column Inlinedrive ID11 (in mm)

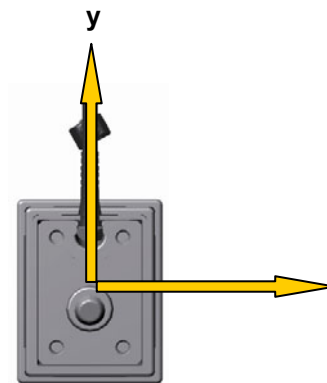

Figure 28 From above (top end) with coordinate system

12.3 Labelling on the products





- ▶ The ratings plate shown is an example; the values shown in the figure may therefore differ from the data relating to your configuration.

Control unit ratings plate

A ratings plate (or type label) on each control unit specifies the exact name and serial number of the drive. It also states the technical specifications valid for that particular control unit. The following illustration shows where the specifications are located on the rating plate of the control unit.





Figure 29 Ratings plate for Motion Manager 3 control unit (example)

| | |
|---|---|
| Motion Manager 3 | Model name |
| xxxxx | Article number |
| 100V – 240V ~ 50/60Hz | Input voltage and frequency |
| max. 4.00A | Rating of fuse |
| Intermittent Operation 2min/18min | Intermittent operations: 2 minutes / 18 minutes |
| Prod.date | Calendar week / year |
| Serial No. | Serial number for the Motion Manager 2 control unit |
| Vx.xx | Software version |
| IP20 | Protection degree |
|  | Use in dry rooms only! |
|  | Protection class II |
|  | Follow all special disposal instructions! |
|  | Conformity mark |

Control keypad ratings plates



Figure 30 Rating plates (examples)



| | |
|---|---|
| M. Assist | Type designation (abbreviation) |
| Motion Assist Pro | Model name |
| xxxxx | Article number |
| U in: 24V = | Input voltage |
| Prod.date 28/10 | Calendar week / year |
| Vx.xx | Software version |
| Serial No. | Serial number of the handset |
| IP20 | Protection degree |
|  | Use in dry rooms only! |
|  | Follow all special disposal instructions! |
|  | Conformity mark |

Rating plate of the ID11 lifting columns

A rating plate or "type label" on each lifting column specifies the exact name and serial number of the drive. It also states the technical specifications valid for that particular lifting column. The following illustration shows where the specifications are located on the drive's ratings plate.



Figure 31 Ratings plate example

| | |
|---|---------------------------------------|
| ID11 | Model name |
| xxxxx | Article number |
| Date | Production date: Calendar week / year |
| Serial | Serial number for your drive |
|  | Follow special assembly instructions! |
|  | Conformity mark |

13. Disposal

The Inlinedrive ID11 System consists of electronic components, cables and metal and plastic parts. You should observe all corresponding national and regional environmental regulations when disposing of the system.

The disposal of the end product is regulated in Germany by Elektro-G, internationally by the EU Directive 2002/95/EC (RoHS, from 01/07/2006), or by any applicable national laws and regulations. (The end product is not regulated by the EU Directive 2002/96/EC (WEEE) and its amendment EU Directive 2003/108/EC.)



The Inlinedrive ID11 System should not be disposed of with normal household waste!

EU Declaration of Conformity

In compliance with Appendix IV of the EU EMC Directive 2004/108/EC

The manufacturer:

DEWERT Antriebs- und Systemtechnik GmbH

Weststraße 1

32278 Kirchlengern

Germany

declares that the following products

Motion Assist with DEWERT drive system
Motion Assist Pro with DEWERT drive system

meet the requirements of the following EU directives:

Electromagnetic Compatibility Directive 2004/108/EC

Applied standards:

- EN 55014-1/A1:2009
- EN 55014-2/A2:2008
- EN 61000-3-2/A2:2009
- EN 61000-3-3:2008

This declaration of conformity is no longer valid if constructional changes are made which significantly change the keypad (i.e., which influence the technical specifications found in the instructions or the intended use)!



Kirchlengern, on the 09.12.2011

Sascha Koltzenburg
Head of R & D

EU Declaration of Conformity

In compliance with Appendix IV of the EU EMC Directive 2004/108/EC

In compliance with Appendix III of the EU Low Voltage Directive 2006/95/EC

The manufacturer:

DEWERT Antriebs- und Systemtechnik GmbH

Weststraße 1

32278 Kirchlengern

Germany

declares that the following products

Motion Manager 2 control unit
Motion Manager 3 control unit

meets the requirements of the following EU directives:

Electromagnetic Compatibility Directive 2004/108/EC

Low Voltage Directive 2006/95/EC

Applied standards:

- EN 55014-1/A1:2009
- EN 55014-2/A2:2008
- EN 61000-3-2/A2:2009
- EN 61000-3-3:2008
- EN 60335-1/A14:2010
- EN 62233:2008

This declaration of conformity is no longer valid if constructional changes are made which significantly change the control unit (i.e., which influence the technical specifications found in the instructions or the intended use)!

Kirchlengern, on the 09.12.2011



Sascha Koltzenburg
Head of R & D

Declaration of Incorporation/Installation

According to Appendix II of the EU Machinery Directive 2006/42/EC

The manufacturer:

DEWERT Antriebs- und Systemtechnik GmbH

Weststraße 1

32278 Kirchlengern

Germany

declares that the incomplete machine described below

Inlinedrive ID11

complies with the following basic requirements of the Machinery Directive (2006/42/EC):

Sections: 1.1.3; 1.3.3; 1.3.4; 1.3.7; 1.5.1; 1.5.2; 1.5.5; 1.5.6; 1.5.7; 1.5.8;
1.5.9; 1.5.10; 1.5.13; 1.6.3

You may only operate this machine after you have confirmed that the end product (into which this drive will be installed) complies with the Machinery Directive 2006/42/EC.

On request, the manufacturer is obliged to send the special documentation accompanying the partially completed machinery electronically to the appropriate national institution. The special technical documents corresponding to the machine have been created according to Appendix VII, part B.

The following person is responsible for the technical documentation: Sascha Koltzenburg,

Address cited above.

Tel: 05223 979329



Kirchlengern, on the 09.12.2011

Sascha Koltzenburg

Head of R & D

EU Declaration of Conformity

In compliance with Appendix IV of the EU EMC Directive 2004/108/EC

In compliance with Appendix III of the EU Low Voltage Directive 2006/95/EC

The manufacturer:

DEWERT Antriebs- und Systemtechnik GmbH

Weststraße 1

32278 Kirchlengern

Germany

declares that the following product

Inlinedrive ID11

meets the requirements of the following EU directives:

Electromagnetic Compatibility Directive 2004/108/EC

Low Voltage Directive 2006/95/EC

Applied standards:

- EN 55014-1/A1:2009
- EN 55014-2/A2:2008
- EN 61000-3-2/A2:2009
- EN 61000-3-3:2008
- EN 60335-1/A14:2010
- EN 62233:2008

This declaration of conformity is no longer valid if constructional changes are made which significantly change the lifting column (i.e., which influence the technical specifications found in the instructions or the intended use)!

Kirchlengern, on the 09.12.2011



Sascha Koltzenburg

Head of R & D

OKIN Motion Technologies GmbH
Friedrich-Ebert-Straße im Campus 1
51429 Bergisch Gladbach, Germany
Tel: +49(0)2204/48022-0
Fax.: +49(0)2204/48022-118
<http://www.okin.de>
Info@okin.de

ID No.: 68016